

Art.: 3056

Válvula de esfera empotrar, extremos roscados Built-in ball valve, threaded ends

Características

1. Válvula esfera empotrar, PN-25, paso total.
2. Construcción en latón s/ UNE-EN 12165.
3. Doble junta tórica NBR en el eje.
4. Extremos roscados hembra BSP (Gas) según ISO 228/1.
5. Temperatura trabajo desde 0°C a 90°C.
6. Adaptable a los mandos M3053, M3053S, M3054, M3055 y prolongador K3052.

Features

1. Built-in ball valve, PN-25, full bore.
2. Brass according to UNE-EN 12165.
3. Double NBR O-ring on the stem.
4. Female threaded BSP (Gas) ends according to ISO 228/1.
5. Working temperature from 0°C to 90°C.
6. Suitable for handles M3053, M3053S, M3054, M3055 and K3052 stretcher.

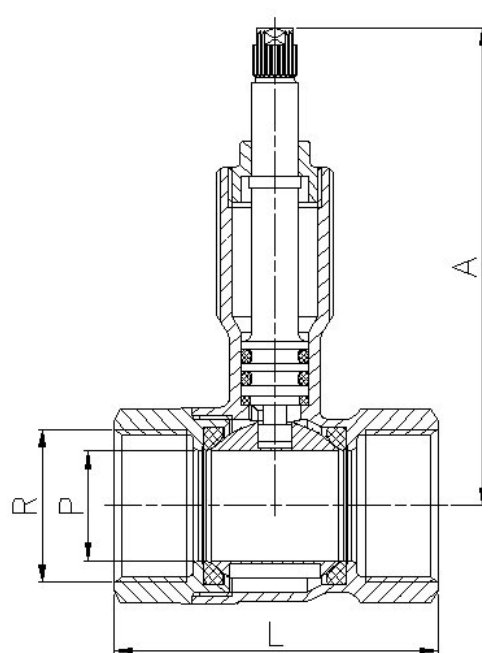
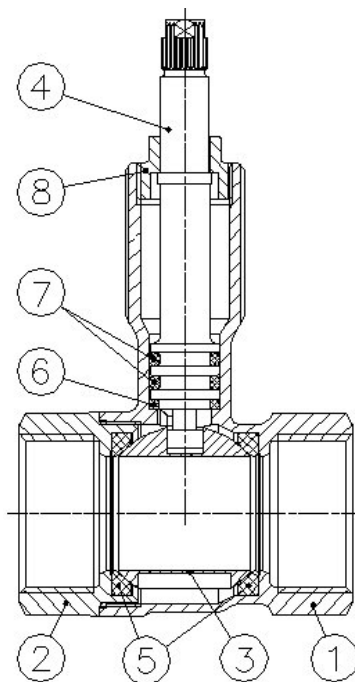

Nº	Denominación / Name	Material	Acabado Superficial / Surface Treatment
1	Cuerpo / Body	Latón / Brass (CW617N)	Granallado / Peened
2	Tapa / Cap	Latón / Brass (CW617N)	Granallado / Peened
3	Esfera / Ball	Latón / Brass (CW617N)	Cromado / Chromed
4	Eje / Stem	Latón / Brass (CW617N)	-
5	Asientos / Ball seats	PTFE	-
6	Anillo prensa / Stem packing	PTFE	-
7	Junta Tórica / O-Ring	NBR	-
8	Tuerca prensa / Packing nut	Latón / Brass	-

Ref.	Medida / Size	Dimensiones / Dimensions (mm)				Peso / Weight (g)
		DN	P	A	L	
3056 04	1/2"	15	14	79	49	175
3056 05	3/4"	20	19	82	56	240
3056 06	1"	25	24	86	68	375