

Art.: 4020

Electroválvula 2/2 Vías N.C. Acción Indirecta

2/2 Ways N.C. with Pilot Control Solenoid Valve

Características

EV con acción indirecta adaptada para la interceptación de los fluidos compatibles con los materiales en que están construidas.

Es solicitada una presión mínima de 0,2 bar para su funcionamiento.

Los materiales utilizados y las pruebas en que son sometidas garantizan fiabilidad y duración.

Temperatura ambiente desde -10°C a 60°C.

APLICACIONES:

- Automatización
- Calefacción

CONEXIONES:

- G3/8" – G2"

BOBINAS

- 8W - Ø 13
- 155°C (clase F)

Features

Solenoid valve with pilot control for interception of fluids compatible with the construction materials.

A minimum operational pressure of 0,2 bar is required.

The materials used and the tests carried out ensure maximum reliability and duration.

Ambient temperature from -10°C to 60°C.

USE:

- Automation,
- Heating

PIPES:

- G 3/8" - G 2"

COILS:

- 8W - Ø 13
- 155°C (class F)



Juntas-Gaskets	Temperaturas-Temperature		Fluidos-Medium
B = NBR (nitrilo)	- 10°C	+ 90°C	Agua, aire, gases inertes Air, inert gas, water
E = EPDM (etileno-propileno)	- 10°C	+140°C	Agua, vapor a baja presión Water, low pressure steam
V = FKM (elastómerofluorado)	- 10°C	+140°C	Aceites ligeros (2°E), gasolina, gasóleo mineral Oils (2°E), gasoline, gas oil

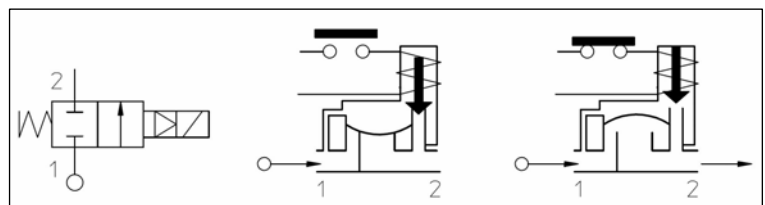

Rosca-Thread ISO 228/1	Código Code	Viscosidad máx. admisible Max viscosity		Ø mm	Kv L/min	Potencia Power (watt)	Presiones / Pressure		
		cSt	°E				mín bar	máx M.O.P.D.	
								AC bar	DC bar
G 3/8"	4020 03	12	~ 2	13	60	8	0,2	16	16
G 1/2"	4020 04				70				
G 3/4"	4020 05			19	140			16	16
G 1"	4020 06			25	190				
G 1 1/4"	4020 07			35	400			10	10
G 1 1/2"	4020 08			40	520				
G 2"	4020 09			50	750				

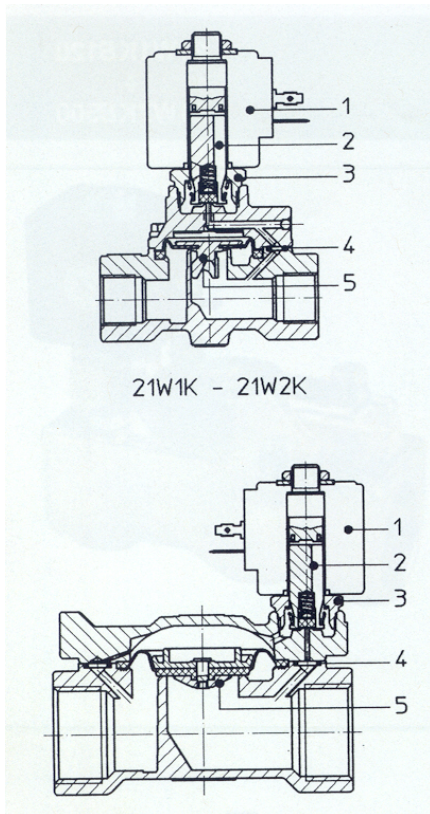

MATERIALES / MATERIALS					
Nº	Denominación / Name	Material			
1	Cuerpo Body	Latón Brass			CW617N EN 12165
2	Tubo Guía Welded armature tube	Acero Inox	Stainless steel		AISI serie 300
3	Núcleo fijo Fixed core	Acero Inox	Stainless steel		AISI serie 400
4	Núcleo móvil Plunger	Acero Inox	Stainless steel		AISI serie 400
5	Anillo de desfase Phase displacement ring	Cobre Copper			Cu 99,9%
6	Muelle Spring	Acero Inox	Stainless steel		AISI serie 300
7	Obturator Seal			Standard B = NBR	
				Bajo pedido V = FKM	
				On request E = EPDM	
8	Orificio Orifice	Latón Brass			CW617N EN 12165
BAJO PEDIDO / ON REQUEST					
Conector	Conector	Pg 9 ó Pg 11			
Conformidad conector	Conector conformity	ISO 4400			

CARACTERÍSTICAS / FEATURES			
Conformidad eléctrica		Electrical conformity	IEC 335
Grado de protección		Protection degree	IP 65 EN 60529 (DIN 40050) Con la bobina provista de conector - With coil fitted by connector
ELEMENTOS DE RECAMBIO – SPARE PART			
1	Bobina	Coil	Véase valores – See page
2	Conjunto núcleo móvil	Complete plunger	EO 20 B
3	Conjunto tubo guía	Complete armature tube	EO 25
4	Cjto. membrana	Complete diaphragm	
		3/8" – 1/2"	EO 21 B
		3/4" – 1"	EO 22 B
		1 1/4" – 1 1/2"	EO 23 B
		2"	EO 24 B

DIMENSIONES - DIMENSIONS

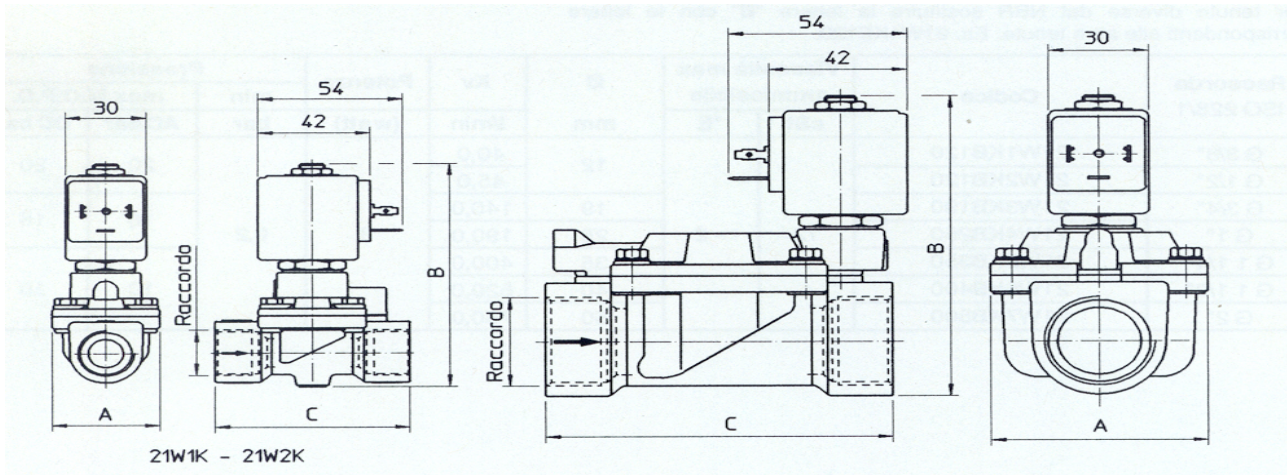

Ref.	Racord- Pipe ISO 228/1	A	B	C
		mm	mm	mm
4020 03	G 3/8"	40	97	60
4020 04	G 1/2"			66
4020 05	G 3/4"	65	105	104
4020 06	G 1"		112	
4020 07	G 1 1/4"	98	125	144
4020 08	G 1 1/2"			
4020 09	G 2"	118	141	172

POTENCIA BOBINA – COIL POWER ABSORPTION		
W =	En el arranque- Inrush VA ~	Trabajo- Hold VA ~
8 W	25	14,5